



IO-Link

## Relative pressure transmitter Type 520 IO-Link



 **IO-Link**

The pressure transmitter Type 520 for industrial applications impresses with its compact and robust design as well as high accuracy and reliability. The hermetically welded stainless steel sensor offers very high overpressure safety and is suitable for use in gases, liquids and all common refrigerants including ammonia.

Huba Control offers with the Type 520 a universally applicable pressure transmitter with IO-Link communication technology. IO-Link is a standardized, digital point-to-point connection that allows the user to easily wire the unit and access a wide range of specific device and process data. IO-Link offers numerous possibilities for device diagnostics, allowing the status of the pressure transmitter to be continuously monitored.

This makes the 520 IO-Link the ideal pressure transmitter for your Industry 4.0 application.

### Pressure range

**-1 ... 9 bar /**

**0 ... 2.5 – 1000 bar**

- + Compact, rugged construction
- + Welded without sealing parts, no elastomer seals
- + Communication via IO-Link 1.1 (Smart Sensor Profile ED2)
- + Sensor diagnosis function
- + High flexibility of process connections

## Technical overview

### Pressure range

Relative -1 ... 9 bar / 0 ... 2.5 - 1000 bar

### Operating conditions

Medium Liquids, gases and refrigerants (incl. ammonia)

Temperature Medium -40 ... +100 °C

Ambient -30 ... +85 °C

Storage -50 ... +100 °C

Tolerable overload ≤ 6 bar 5 x fs

> 6 bar 3 x fs (max. 1500 bar)

Rupture pressure ≤ 6 bar 10 x fs

> 6 bar 6 x fs (max. 2500 bar)

### Materials

Cover Stainless steel 1.4404 / AISI 316L

Plug accommodation Polyarylamide 50% GF UL 94 V-0

Materials in contact with medium Pressure connection Stainless steel 1.4404 / AISI 316L (inside thread Schrader 1.4305 / AISI 303)

Sensor Stainless steel

### Electrical overview

4 wire Output Power supply Permanent current load Current consumption

IO-Link 18 ... 33 VDC 100 mA per switching output < 15 mA<sup>2)</sup>

Polarity reversal protection Short circuit proof and protected against polarity reversal. Each connection is protected against crossover up to max. supply voltage.

Insulation voltage 500 VDC

### IO-Link

Specification V1.1

Port type Class A

Baud rate COM2 (38.4 k Baud)

Output function PNP, NPN, PushPull

Offset

Filter

Switching points

Programming options Hysteresis- / filter function, N/C contact or N/O contact

min./max. pressure value, pressure peak counter

Operating hours counter

### Dynamic response

Startup time 50 ms

Response time typ. < 2 ms

Process cycle time < 3.3 ms

Load cycle < 100 Hz

### Electrical connection

Connector M12x1

### Protection standard

IP 67

### Protection class

III

### Pressure connection

Inside thread  $\frac{7}{16}$ -20 UNF without or with Schrader

$\frac{1}{2}$ -14 NPT (≤ 60 bar)

G  $\frac{1}{4}$  with O-Ring seal FPM (-30 ... +135 °C)

$\frac{7}{16}$ -20 UNF sealing cone

$\frac{1}{4}$ -18 NPT

$\frac{7}{16}$ -20 UNF sealed at back SAE 4 with O-Ring seal FPM (-20 ... +135 °C)

G  $\frac{1}{4}$  sealed at back DIN 3852-E with profile seal ring in FPM (-30 ... +135 °C)

G  $\frac{1}{4}$  sealed at back and manometer (combi) with profile seal ring in FPM (-30 ... +135 °C) (≤ 60 bar)

Outside thread R  $\frac{1}{4}$  EN 10226

G  $\frac{1}{2}$  sealed at back and manometer (combi) with profile seal ring in FPM (-30 ... +135 °C)

$\frac{1}{8}$ -27 NPT (≤ 60 bar)

G  $\frac{1}{8}$  sealed at front (≤ 60 bar)

G  $\frac{1}{8}$  sealed at back DIN 3852-E with profile seal ring in FPM (-30 ... +135 °C) (> 60 bar)

M10x1 sealed at back DIN 3852-E with Profile seal ring in FPM (-30 ... +135 °C) (≤ 60 bar)

M20x1.5 sealed at front and manometer (combi)

G  $\frac{1}{2}$ , G  $\frac{1}{4}$  sealed at front

### Installation arrangement

Unrestricted

### Tests / Admissions

Electromagnetic compatibility CE conformity acc. EN 61326-2-3

Enhanced EMC protection EN 50121-3-2

Shock acc. IEC 68-2-27 100 g, 11 ms half sine wave, all 6 directions, free fall from 1 m on concrete (6x)

Constant shock acc. IEC 68-2-29 40 g for 6 ms, 1000x all 3 directions

Vibration acc. IEC 68-2-6 20 g, 15 ... 2000 Hz, 15 ... 25 Hz with amplitude ± 15 mm, 1 Octave/min. all 3 directions, 50 constant load

UL ANSI/UL 61010-1 acc. E325110

EAC

### Weight

~ 90 g

### Packaging (Please state on order)

Single packaging in cardboard

accessories integrated

Multiple packaging in cardboard (25 pcs)

<sup>1)</sup> without switching output

<sup>2)</sup> typ.; max. 25 mA

## Accuracy

Parameter		Unit	
Characteristic line <sup>1)</sup>		% fs	± 0.3
Resolution		% fs	0.1
Thermal characteristic <sup>2)</sup>	max.	% fs/10K	± 0.2
Long term stability acc. IEC EN 60770-1	max.	% fs	± 0.25

Test conditions: 25 °C, 45% RH, power supply 24 VDC

Order code selection table in bar			1	2	3	4	5	6	7	8	9	10	
			520.	X	X	X	X	X	X	X	X	X	
Pressure range <sup>3)</sup>	-1 ... 9 bar		9	0	6								
	0 ... 2.5 bar		9	1	4								
	0 ... 4 bar		9	1	5								
	0 ... 6 bar		9	1	7								
	0 ... 10 bar		9	3	0								
	0 ... 16 bar		9	3	1								
	0 ... 25 bar		9	3	2								
	0 ... 40 bar		9	3	3								
	0 ... 60 bar		9	4	0								
	0 ... 100 bar		9	4	1								
	0 ... 160 bar		9	4	2								
	0 ... 250 bar		9	4	3								
	0 ... 400 bar		9	5	4								
	0 ... 600 bar		9	5	5								
0 ... 1000 bar		9	5	7									
Application	standard					S	0						
Output / power supply	IO-Link	18 ... 33 VDC						L					
Electrical connection	M12x1	4L: L+=1 / L-=3 / C/Q=4 / DI/DQ=2							P				
Pressure connection <sup>3)</sup>	Inside thread	<sup>7</sup> / <sub>16</sub> -20 UNF sealing cone with schrader								0	0	N	
		<sup>7</sup> / <sub>16</sub> -20 UNF sealing cone								K		1	
		<sup>1</sup> / <sub>2</sub> -14 NPT <sup>5)</sup>									D		1
		G <sup>1</sup> / <sub>4</sub> with O-Ring seal FPM									1		1
	Outside thread	<sup>7</sup> / <sub>16</sub> -20 UNF sealing cone									2		1
		<sup>1</sup> / <sub>4</sub> -18 NPT									3		1
		G <sup>1</sup> / <sub>4</sub> sealed at back DIN 3852-E with profile seal ring in FPM									4		1
		G <sup>1</sup> / <sub>4</sub> sealed at back and manometer with profile seal ring in FPM									5	0	1
		R <sup>1</sup> / <sub>4</sub> acc. to EN 10226									7		1
		G <sup>1</sup> / <sub>2</sub> sealed at back and manometer with profile seal ring in FPM									8		1
		<sup>7</sup> / <sub>16</sub> -20 UNF sealed at back SAE 4 with O-Ring seal FPM									G		1
		<sup>1</sup> / <sub>8</sub> - 27 NPT <sup>5)</sup>									A		1
		G <sup>1</sup> / <sub>8</sub> sealed at front <sup>5)</sup>									M		1
		G <sup>1</sup> / <sub>8</sub> sealed at back DIN 3852-E with Profile seal ring in FPM <sup>6)</sup>									H		1
		M10x1 sealed at back DIN 3852-E with profile seal ring in FPM <sup>5)</sup>									F		1
		M20x1.5 sealed at front and manometer (combi)									E		1
G <sup>1</sup> / <sub>4</sub> sealed at front									J		1		
G <sup>1</sup> / <sub>2</sub> sealed at front									9		1		
Pressure orifice	without (inclusive pressure tip orifice from 100 bar on)										0		
	with										2		
Material	Stainless steel 1.4305 / AISI 303											N	
pressure connection	Stainless steel 1.4404 / AISI 316L											1	

<sup>1)</sup> typ. ; max. 0.5% fs (incl. zero point, full scale, linearity, hysteresis and repeatability)  
<sup>5)</sup> (≤ 60 bar)

<sup>2)</sup> -15 ... 85 °C

<sup>3)</sup> Other pressure ranges or pressure connections on request

<sup>4)</sup> Delivery without female connector

<sup>6)</sup> Rupture pressure 1000 bar

Corner-wire box for connector M12x1 with cable 2.0 m	114604
Straight-wire box for connector M12x1 with cable 2.0 m	114605
Mounting bracket with screw	118716
Heat sink with outside thread G ½ sealed at front - inside thread G ½	105631
Heat sink with outside thread G ½ sealed at front - inside thread G ¼	105073
Heat sink with outside thread G ¼ sealed at front - inside thread G ¼	105074
Calibration certificate (≤ 600 bar)	104551

Mounting bracket

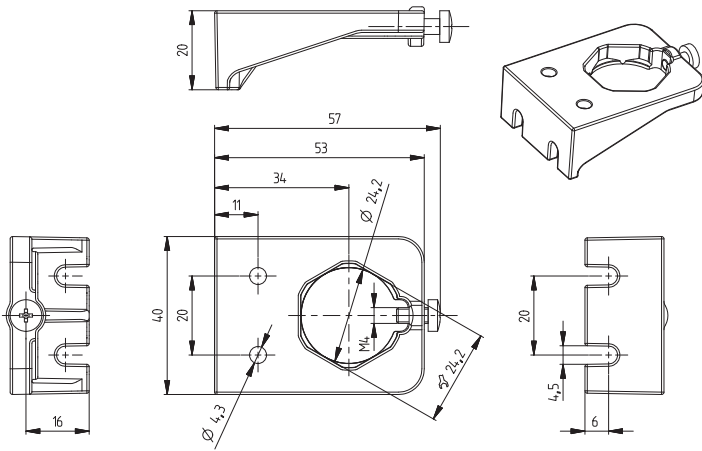

Heat sink

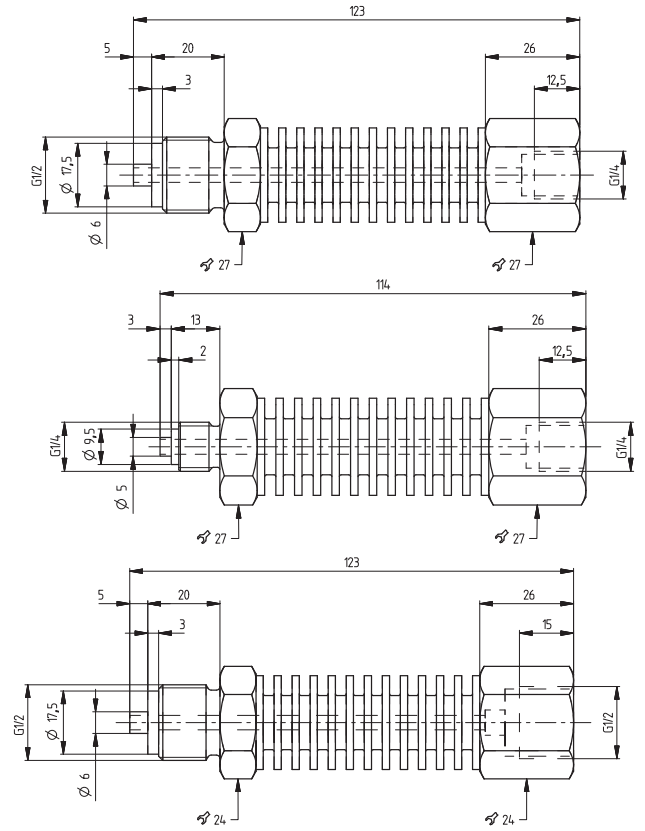

## Dimensions in mm

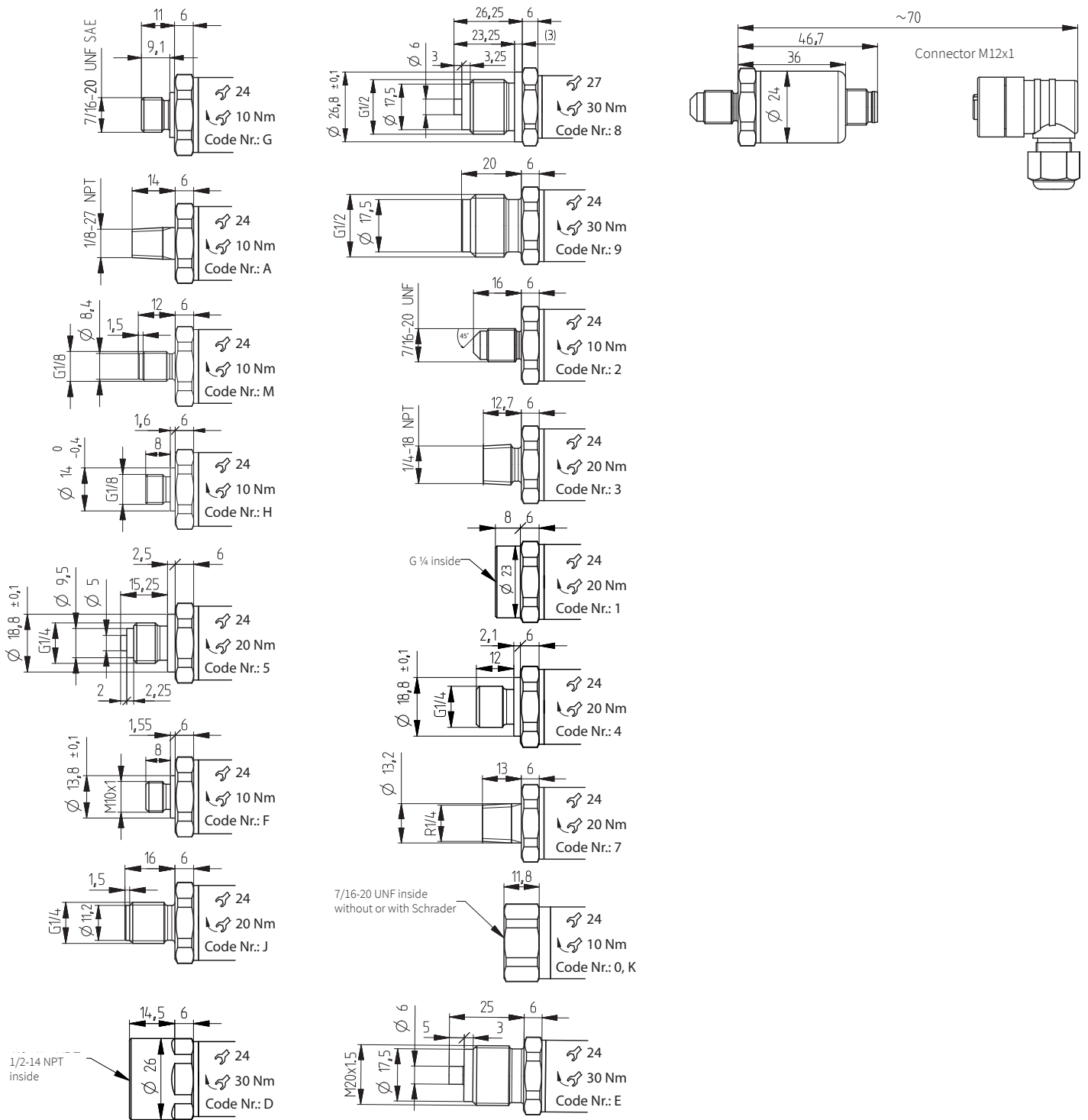

## Electrical connections

### 4 wire

Connector M12x1

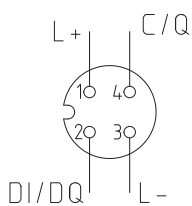

Legend:  
 L+ = power supply +  
 L- = power supply -  
 C/Q = IO-Link/switching output 1  
 DI/DQ = switching output 2

**Huba Control AG**

Headquarters Schweiz  
Industriestrasse 17  
CH-5436 Würenlos  
Telefon +41 56 436 82 00  
Fax +41 56 436 82 82  
info.ch@hubacontrol.com

**Huba Control AG**

Niederlassung Deutschland  
Schlattgrabenstrasse 24  
D-72141 Walddorfhäslach  
Telefon +49 7127 2393 00  
Fax +49 7127 2393 20  
info.de@hubacontrol.com

**Huba Control AG**

Vestiging Nederland  
Hamseweg 20A  
NL-3828 AD-Hoogland  
Telefoon +31 33 433 03 66  
Telefax +31 33 433 03 77  
info.nl@hubacontrol.com

**Huba Control SA**

Succursale France  
Rue Lavoisier  
Technopôle Forbach-Sud  
F-57602 Forbach Cedex  
Téléphone +33 3 87 84 73 00  
Télécopieur +33 3 87 84 73 01  
info.fr@hubacontrol.com

**Huba Control AG**

Branch Office United Kingdom  
Unit 13 Berkshire House, County Park  
Business Centre, Shivenham Road  
Swindon - Wiltshire SN1 2NR  
Phone +44 1993 77 66 67  
Fax +44 1993 77 66 71  
info.uk@hubacontrol.com

**[www.hubacontrol.com](http://www.hubacontrol.com)**

